

User Manual

The logo for Crane Fitness, featuring a stylized white crane in flight above the word "Crane" in a white, italicized sans-serif font, all contained within a black rounded rectangular shape.

Crane

ADJUSTABLE HAND GRIPS



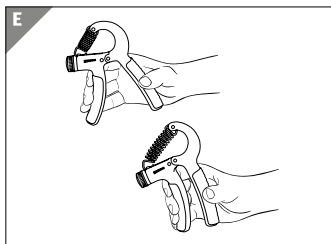
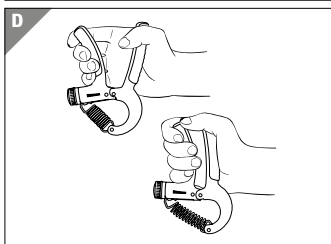
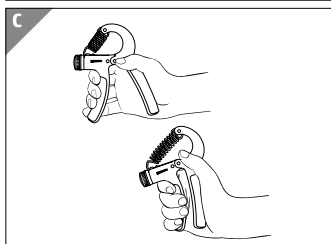
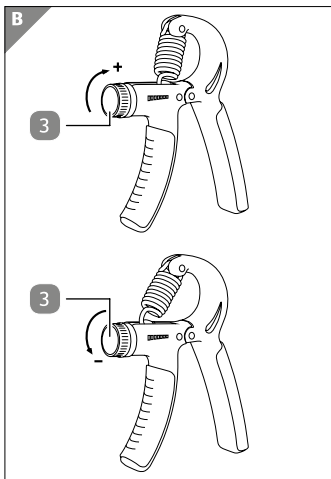
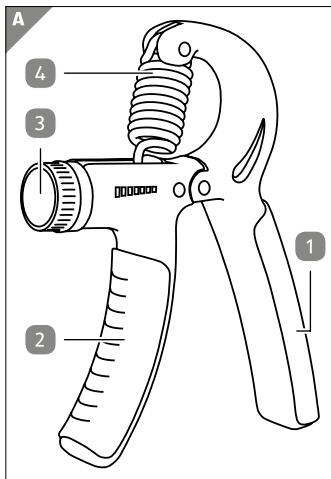

Scope of supply / parts

- 1 Rear grip
- 2 Front grip
- 3 Adjustment knob
- 4 Spring

Table of contents

Overview	2
Use.....	2
Scope of supply / parts	3
General information.....	5
Read and keep operating instructions	5
Explanation of symbols	5
Safety	6
Intended use	6
Safety information	6
Inspection of the adjustable hand grips and scope of supply ...	8
Using the adjustable hand grips.....	9
Set training resistance.....	9
Exercises.....	9
Cleaning and storage	10
Technical data	11
Disposal	11
Disposal of the packaging	11
Disposal of the adjustable hand grips.....	11

General information

Read and keep operating instructions



These operating instructions belong to this adjustable hand grips. They contain important information about safety and handling

Read the operating instructions, particularly the safety information, carefully before using the adjustable hand grips. Non-compliance with these operating instructions can lead to serious injuries and damage to the adjustable hand grips.

The operating instructions are based on the valid norms and rules in the European Union. Please also note the country-specific guidelines and laws abroad.

Please keep the operating instructions for further use. If you pass on the adjustable hand grips to third parties, please ensure that you include these operating instructions.

Explanation of symbols

The following symbols and signal words are used in these operating instructions, on the adjustable hand grips or on the packaging.



This signal symbol/word indicates a hazard with a medium level of risk which, if not avoided, may result in death or serious injury.



This signal symbol/word indicates a hazard with a low level of risk which, if not avoided, may result in minor or moderate injury.

NOTE!

This signal word warns of possible property damage.



This symbol provides you with useful additional information about assembly or handling.

Safety

Intended use

The adjustable hand grips are designed for the fitness area. It is exclusively intended for private use and is not suitable for commercial use. The adjustable hand grips are not a toy.

Only use the adjustable hand grips as described in these operating instructions. Any other use is regarded as not being as intended and can lead to material damage.

The manufacturer or retailer shall not accept any liability for damage, which is caused by non-intended use or incorrect use.

Safety information



Hazards for children and persons with impaired physical, sensory or mental

capabilities (for example, partly disabled, older persons with impaired physical and mental capabilities) or a lack of experience and knowledge (for example, older children).

- These adjustable hand grips can be used by children from the age of eight and above, as well as by persons with impaired physical, sensory or mental capabilities or a lack of experience and knowledge, if they are supervised or have been briefed on the safe use of the adjustable hand grips and the resulting hazards. Children are not permitted to play with the adjustable hand grips.
- Do not let children play with the packaging film. Children can swallow it when playing and suffocate.



Risk of injury!

You can injure yourself on the adjustable hand grips, if you use it improperly.

- Ensure that you do not reach into the spring with your fingers, when they are pull apart. There is a risk of crushing.
- Prior to any use, ensure that the adjustable hand grips do not show any damage. Do not use the adjustable hand grips, if they are damaged.

Inspection of the adjustable hand grips and scope of supply

NOTE!

Risk of damage!

If you open the packaging carelessly using a sharp knife or other sharp objects, the adjustable hand grips can become damaged.

- Proceed carefully when opening.
 1. Remove the adjustable hand grips from the packaging.
 2. Check whether the delivery is completed (see **Fig. A**).
 3. Check whether the adjustable hand grips or the individual parts show any damage. If this is the case, do not use the adjustable hand grips. Contact the manufacturer via the service address.

Using the adjustable hand grips

Set training resistance

- Turn the adjustment knob ③ (see **Fig. B**)
- clockwise to increase the training resistance. You will need more strength for training.
- anti-clockwise, to reduce the training resistance. You will need less strength for training.

Exercises

Exercise 1

1. Hold the adjustable hand grips in your hands such that the rear grip ① is in contact with the ball of the thumb and your fingers are holding around the front grip ② (see **Fig. C**).
The spring ④ will face upwards.
2. Squeeze the adjustable hand grips together.
3. Perform the exercise three times with 20 repetitions each.

Exercise 2

1. Hold the adjustable hand grips in your hands such that the rear grip ① is in contact with the ball of the thumb and your fingers are holding around the front grip ② (see **Fig. D**).
The spring ④ will be facing upwards.
2. Squeeze the adjustable hand grips together.
3. Perform the exercise three times with 20 repetitions each.

Exercise 3

1. Hold the adjustable hand grips, so that you have your thumb on the rear grip ① and your fingertips are on the front grip ② (see **Fig. E**).
The spring ④ will be facing downwards.
2. Squeeze the adjustable hand grips together.
3. Perform the exercise three times with 20 repetitions each.

Cleaning and storage

NOTE!

Risk of damage!

Improper cleaning can lead to the adjustable hand grips becoming damaged.

- Do not use any aggressive detergents, brushes with metallic or nylon bristles or any sharp or metallic cleaning tools, such as knives, hard spatulas and similar items. These can damage the surfaces.
1. Wipe the adjustable hand grips clean with a slightly dampened cloth. If necessary, use a mild detergent, e.g. fat-soluble dish washing detergent.
 2. Let the adjustable hand grips dry completely before putting them away and if you do not intend to use them for a longer period of time.
 3. Store the adjustable hand grips in a dry place, where they are protected from direct sunlight.

Technical data:

Product Code:	802932
Model:	FLX-FTL-01 / FLX-FTM-01 / FLX-FTH-01
Dimensions:	ca. 15.2 x 11.5 x 2 cm

Model version berry (FLX-FTL-01)

Weight:	ca. 137 g
Training resistance:	2 – 10 kg

Model version turquoise (FLX-FTM-01)

Weight:	ca. 137 g
Training resistance:	5 – 20 kg

Model version grey (FLX-FTH-01)

Weight:	ca. 145 g
Training resistance:	10 – 40 kg

Disposal

Disposal of the packaging



Dispose of the packaging unmixed. Add cardboard and cardboard to the waste paper, foils to the recyclables collection.

Disposal of the adjustable hand grips

- Dispose of the adjustable hand grips in accordance with the valid laws and regulations in your country.

ALDI guarantees that **our exclusive brand** products are developed to our stringent quality specifications. If you are not entirely satisfied with this product, please return it to the nearest ALDI store within 60 days from the date of purchase, for a full refund or replacement.



Made in China

CRANE® is a registered trademark of ALDI Stores

DISTRIBUTED BY:

ALDI STORES

1 SARGENTS ROAD

MINCHINBURY NSW 2770

www.aldi.com.au