

User Manual



SPEED JUMP ROPE



Contents

Overview	3
Use	5
Package contents/parts	6
General information	7
Reading and storing the user manual	7
Explanation of symbols	7
Safety	8
Proper use	8
Safety instructions.....	9
First use	12
Checking Jump Rope and package contents	12
Assembly	12
Workout	13
Warm Up	13
Workout	13
Cool-down	13
Post-stretching.....	13
Exercises	14
One leg jump.....	14
Maintenance and care	15
Storage	15
Technical data	16
Disposal	16
Disposal of packaging.....	16
Disposing of Jump Rope.....	16

A

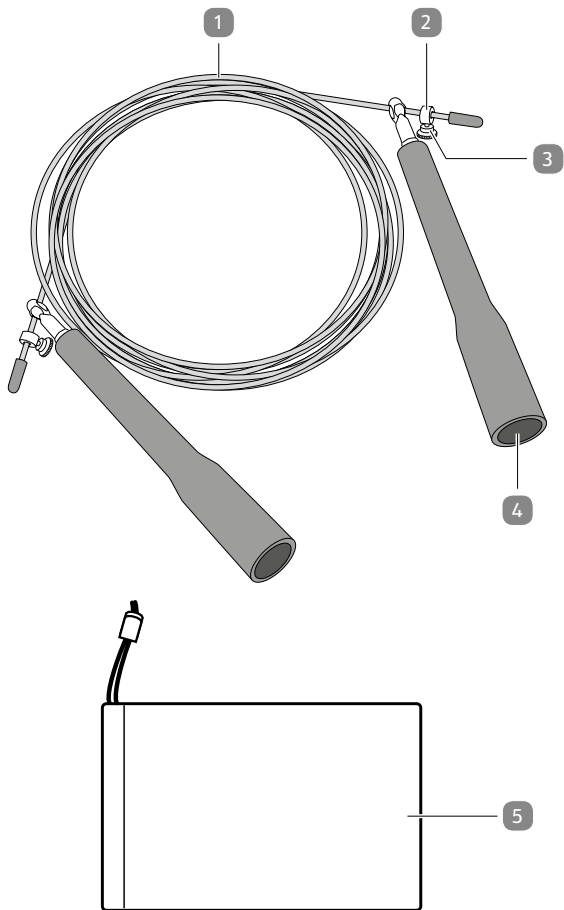

B

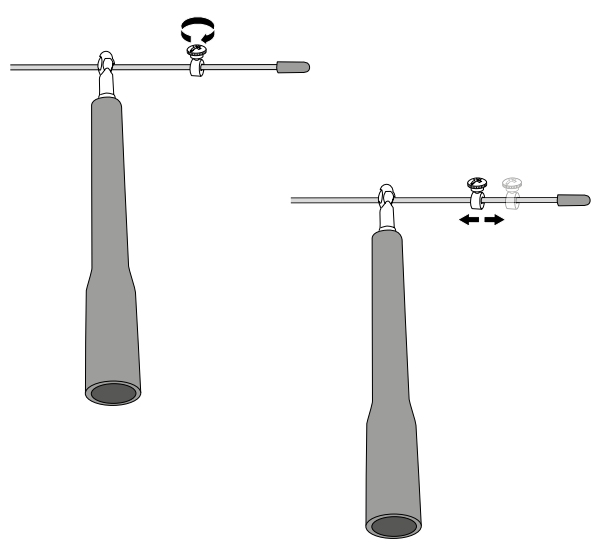

C

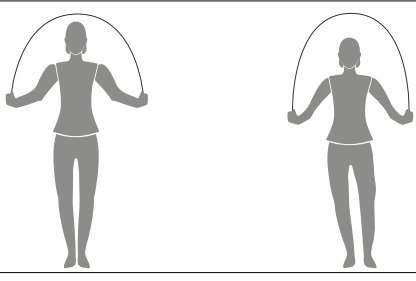

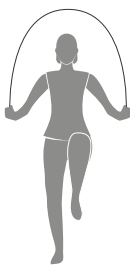
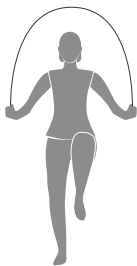
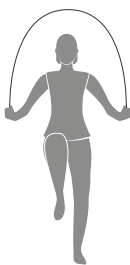
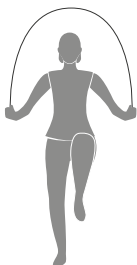
D**E**

Package contents/parts

- 1 rope
- 2 knurled screw, 2×
- 3 locking ring, 2×
- 4 handle, 2×
- 5 storage bag

General information

Reading and storing the user manual



This user manual accompanies this Speed Jump Rope (hereafter referred to as the jump rope), and contains important information on setup and handling. Before using the jump rope, read the user manual carefully. This particularly applies to the safety instructions. Failure to do so may result in personal injury or damage to the jump rope.

Store the user manual for further use. Make sure to include this user manual when passing the jump rope on to third parties.

Explanation of symbols

The following symbols and signal words are used in this user manual, on the jump rope or on the packaging.



WARNING!

This signal symbol/word designates a hazard with a high degree of risk, which will result in death or severe injury if not avoided.



CAUTION!

This signal symbol/word designates a hazard with moderate risk, which may result in death or severe injury if not avoided.

NOTICE

This signal symbol/word warns of possible damage to property.

Safety

Proper use

The jump rope are exclusively designed as training equipment. They are intended exclusively for private use and are not suitable for commercial, medical or therapeutic applications. The jump rope is not a children's toy.

Only use the jump rope as described in this instruction manual. Any other use is considered improper and can lead to material damage.

The manufacturer or retailer shall not accept any liability for damages caused by improper or incorrect use.

Safety instructions



WARNING!

Danger of suffocation!

If children play with the packaging film, they can get caught up in it, put it over their head or swallow it, and thus suffocate.

- Do not let children play with the packaging film. Children can get caught up in it and suffocate while playing.
- Keep children away from the small parts.



WARNING!

Risk of injury!

Improper handling of the jump rope can lead to injuries.

- Be sure to consult your family doctor to determine or prevent any health risks before starting any exercise program. The advice of your physician will determine your pulse rate, blood pressure or cholesterol level.

- Observe your body signals. Improper or excessive training can endanger your health. If at any time during the training you experience pain, chest tightness, irregular heartbeat, extreme shortness of breath, dizziness or drowsiness, stop training immediately and consult your family doctor.
- Keep children and animals away from the jump rope. It is intended for adults only.
- Use the jump rope on a firm, level surface with a protective cover for your floor or carpet. The safety distance should be at least 2 meters all around.
- Before each use, check the jump rope (e.g. for cracks). The safety of the jump rope can only be maintained if they are checked regularly.

**CAUTION!****Risk of injury!**

Improper handling of the jump rope can lead to injuries.

- Always wear suitable clothing during the training. Avoid excessively loose clothing that can get caught on the jump rope.
- Wear suitable shoes with non-slip soles.
- Keep a sufficient distance to other persons and/or objects during the use. Make sure that you do not injure yourself or others when using the product.
- The jump rope may not be used by more than one person at a time.
- The jump rope is not suitable for therapeutic use.

First use

Checking jump rope and package contents

NOTICE

Risk of damage!

If you open the packaging carelessly with a sharp knife or other sharp object, the jump rope can quickly be damaged.

- Be very careful when opening.
1. Remove the jump rope from the packaging.
 2. Check whether the delivery is complete (see **Fig. A**).
 3. Check whether the jump rope or the individual parts are damaged. If this is the case, do not use the jump rope.

Length adjustment

The length of the jump rope is adjustable up to a length of 300 cm. To determine the correct length, proceed as follows:

1. Stand on the middle of the rope with one foot **1**.
The handles **4** should then reach your chest height.
2. Turn the knurled screw **2** (see Fig. B).
3. Move the locking ring **3** to the desired position.
4. Tighten the knurled screw again.

Workout

Warm-up

Your workout should always start with a warm-up. The more strenuous the subsequent training session, the more important it is to warm up. Warming up prepares the body for the strain, stimulates the cardiovascular system and protects ligaments, tendons and joints from injuries. It also helps to reduce the risk of cramps and muscle injuries. You should loosen your joints a little before starting your workout.

Workout

After getting used to the exercises, try to be innovative and develop your own training method. Combine different exercises and listen to music to enjoy your workout even more.

Cool-down

Just as a warm-up should be performed before each training session, a cool-down should be performed after each session. A cool-down initiates the relaxation phase, reduces the body's operating temperature again, and depicts the change from stress to relaxation.

Post-stretching

As mentioned earlier, you can easily pre-stretch your muscles while warming up. After the training you should stretch your muscles. A post-stretching brings the muscle back to its original length and thus prevents muscle shortening. The more strenuous the training, the more important the post-stretching is. Post-stretching is particularly important for the main muscle groups used during training. The stretching should be felt, but it shouldn't be painful. The stretching time is about 20 seconds for each muscle.

Exercises

To warm up for the rope jumping, you can actively pull and stretch your feet and circle them with your hands in addition to the usual exercises. Thereby, make sure to change the direction. Each jump should also first be practiced first without a rope.

Grab the handles loosely in both hands. Keep your shoulders relaxed with your upper body upright, and your elbows close to your body. Your legs should be stretched after the jump and slightly bent when landing.

Turn the jump rope with a wrist movement, and keep your upper body stable while moving the rope over your head. You should only jump exclusively on the ball of your feet, and only as high as necessary. The rope will have slight floor contact with every revolution.

As an advanced user you can try to perform so-called double jumps for faster jumps. Thereby, the jump rope is moved under the feet twice during each jump (see **Fig. C**).

One leg jump

Just jump on one leg only. The other leg can be bent forwards or backwards (see **Fig. D**).

Alternatively, you can change the active leg with each jump. Thereby, the other leg can be bent forwards or backwards (see **Fig. E**).

Maintenance and care

NOTICE

Risk of damage!

Improper handling of the jump rope can lead to damages to the jump rope.

- Do not use aggressive cleaning agents, brushes with metal or nylon bristles or sharp or metallic cleaning objects such as knives, hard spatulas and the like. These can damage the surfaces.
- Wipe the jump rope with a slightly moistened cloth.
- Afterwards allow the jump rope to dry completely.
- Check the jump rope regularly for cracks, damage and wear.

Storage

- Store the jump rope in the enclosed storage bag **5** in a dry place at room temperature and out of the reach of children.

Technical data

Model:	FLX-SPS-01
Item Number:	99522
Weight:	100 g

Jump Rope

Material:	braided silver steel cable with PVC coating
Diameter:	2.5 mm incl. PVC; 1.5 mm +/- 3% without PVC
Length of rope:	up to 300 cm

Rope mount (two ball bearings per handle)

Material:	galvanized steel
Diameter:	7 mm
Length:	27 mm

Handles

Length:	15.3 cm
Diameter:	2.35 cm
Material:	PP

Disposal

Disposal of packaging



Dispose of the packaging sorted by type. Add cardboard to the waste paper, and foils to the recyclables collection.

Disposing of jump rope

- Dispose of the jump rope in accordance with the laws and regulations applicable in your country.

ALDI guarantees that our exclusive brand products are developed to our stringent quality specifications. If you are not entirely satisfied with this product, please return it to the nearest ALDI store within 60 days from the date of purchase, for a full refund or replacement.



Made in China

CRANE® is a registered trademark of ALDI Stores

DISTRIBUTED BY:
ALDI STORES,
1 SARGENTS ROAD,
MINCHINBURY NSW 2770
www.aldi.com.au