



Original Instructions



HYDRAULIC TROLLEY JACK





Contents

Overview	4
Use	5
Total content /parts	6
General information.....	8
Please read and store the instructions	8
Explanation of symbols	8
Safety	9
Correct use	9
Safety instructions	9
First use	14
Check the car jack and the total content	14
General overview	14
Saddle assembling/dismantling	15
Assembling the car jack	16
Fitting the carry handle	16
Assembling the jack handle	16
Attaching the jack handle	16
Car jack use	17
Vehicle preparation.....	17
Car jack placement.....	17
Vehicle lifting	18
Vehicle lowering.....	19
Troubleshooting.....	20
Maintenance, repair and inspection.....	21
Adding oil	22
Changing oil.....	23
Cleaning and storing.....	24
Technical details.....	25
Waste disposal.....	25
Disposal of the packaging.....	25
Disposal of the car jack	25
Declaration of conformity	26

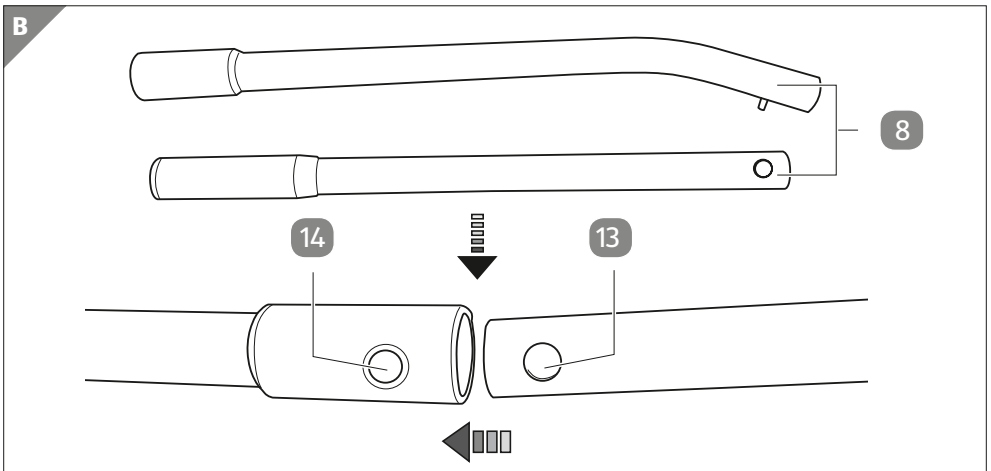
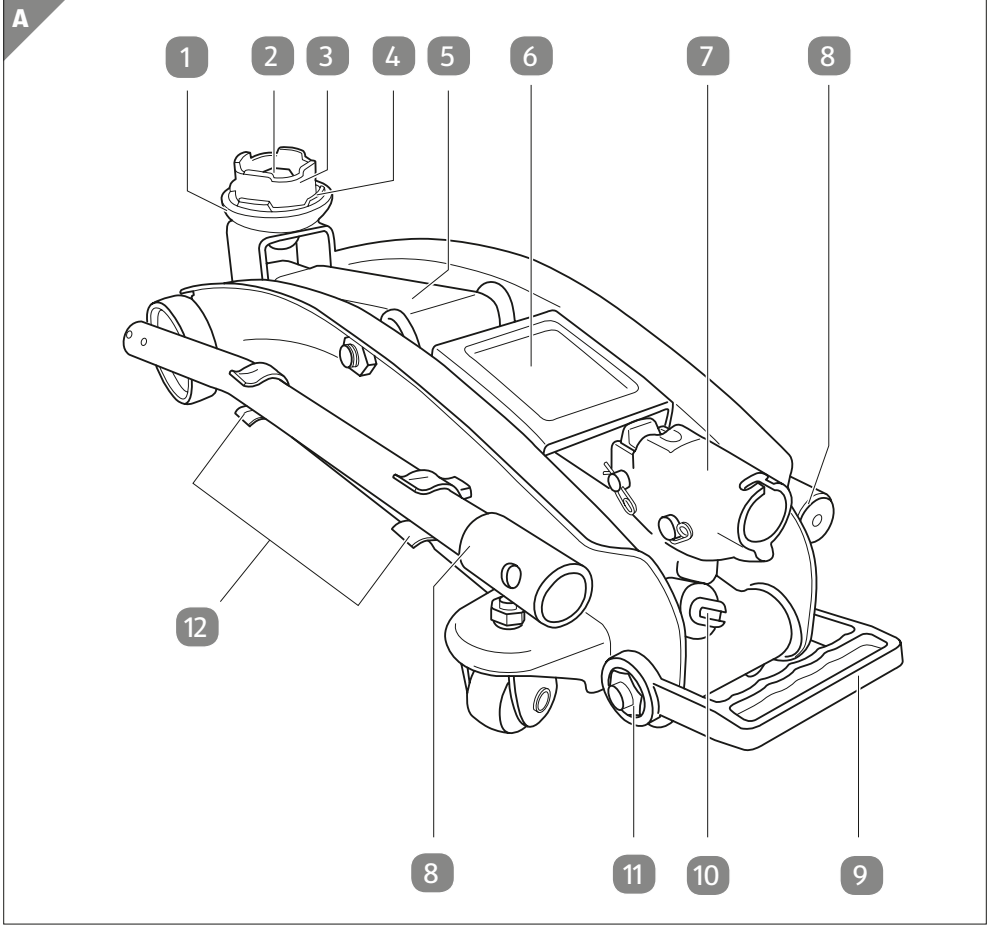

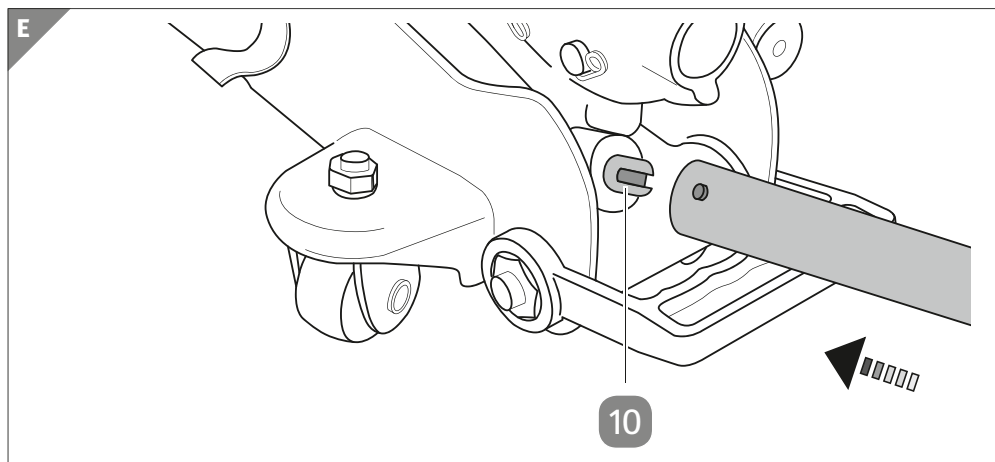
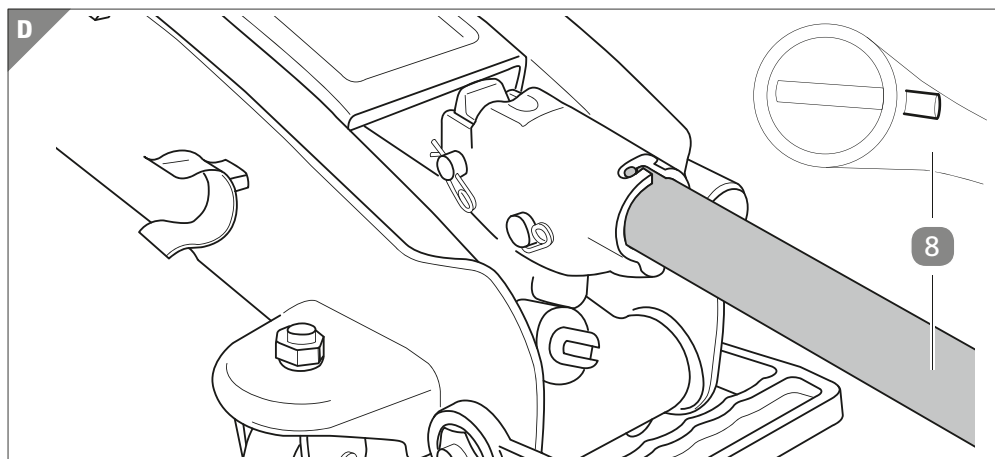
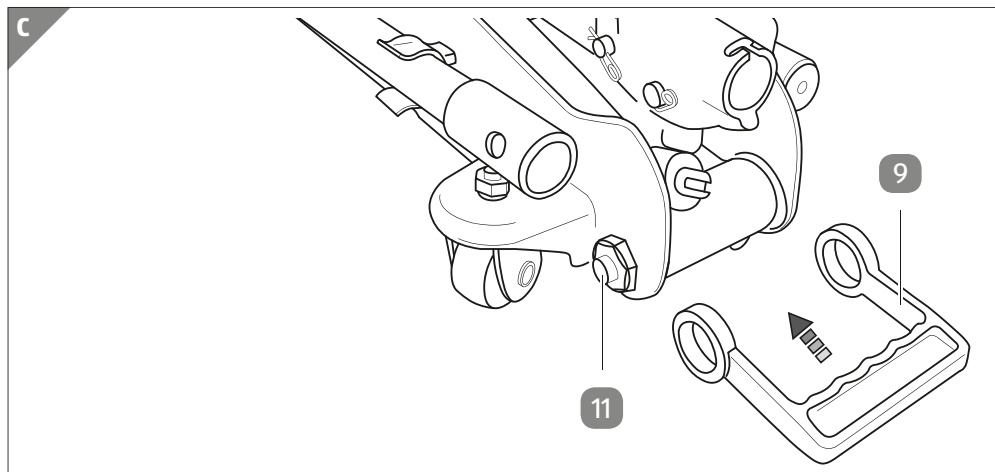

Total content / parts

- 1 Saddle holder
- 2 Saddle bolt
- 3 Saddle sleeve
- 4 Saddle
- 5 Lifting arm
- 6 Cover plate
- 7 Handle sleeve
- 8 Jack handle
- 9 Carry handle
- 10 Release valve
- 11 Carry handle nut
- 12 Jack handle clip, 4×
- 13 Pin
- 14 Drilled hole

– User Manual / Warranty Card

GENERAL INFORMATION

Please read and store the instructions



These instructions for use are valid for this hydraulic trolley jack for vehicles (hereafter referred to as “car jack”), and contain important information of its setup and use.

Before using the car jack, carefully read the instructions.

This applies primarily to the safety instructions. Failure to do so could cause personal injury or damage to the car jack.

Keep the instructions for future reference. If you are handing over the car jack to a third party, you must at the same time hand over these instructions.

Explanation of symbols

The following symbols and words of warning are used in these instructions, on the car jack or on the packaging.



This symbol/warning word indicates danger with a high level of risk, which will, if not avoided, lead to death or serious injuries.



This symbol/warning word indicates danger with a medium level of risk, which will, if not avoided, lead to death or serious injuries.



This symbol/warning word indicates danger with a low level of risk, which will, if not avoided, lead to less serious injuries.



This symbol/warning word warns of the possibility of material damage.



The symbol provides useful additional information on handling and use.



Declaration of conformity (see the “Declaration of conformity” section): Products marked with this symbol fulfil all of the rules, which they must adhere to, of the European Economic Area.



The symbol GS confirms that the product is safe when used correctly. The symbol “GS” means that safety has been checked. Products which are marked with this symbol meet the requirements of German law about the safety of products (ProdSG).



The seal marked ‘Fitness for Use/DEKRA tested’ confirms that the product satisfies the requirements for the properties listed in the logo, in accordance with the DEKRA test program.

SAFETY

Correct use

The car jack is intended solely for short term lifting and lowering of vehicles, whose total weight does not exceed 2 tonnes. The car jack is intended solely for personal use and is not appropriate for commercial purposes.

The car jack is for use only as described in these instructions. Any other use is incorrect and can lead to material damage or personal injury.

Neither the manufacturer nor the retailer can be held responsible for damage or injury as a result of improper or incorrect use.

According to DIN EN 1494: 2009-05 (EN 1494:2000+A1).

Safety instructions



DANGER!

Danger of personal injury!

The car jack should not be used to lift people or animals. This could lead to serious injuries or even death.

- The car jack should only be used for lifting and lowering vehicles.



DANGER!

Danger of personal injury!

To avoid danger, the car jack and the vehicle must always be monitored during use. Failure to do so could lead to serious personal injury or even death.

- Ensure that the car jack and the vehicle are stable. The car jack must be placed on a firm, stable, flat and level surface.
- Ensure that during lifting and lowering the car jack is able to rotate.
- Never lift a vehicle whose total weight exceeds 2 tonnes, even for a short length of time.
- Ensure children and animals are kept away whilst the vehicle is on the car jack.
- Never lift the vehicle if there are passengers inside,
- Make sure the load is supported in the centre of the saddle.
- Support the vehicle with support devices with an adequate load capacity and before carrying out work on the vehicle, remove the car jack.
- When the vehicle is supported by only the car jack, no one should be under the vehicle.



WARNING!

Danger of personal injury!

Before use, the car jack user must fully understand how the car jack functions and the full process for its safe use.

Failure to do so can lead to serious personal injury.

- Before lifting a vehicle, read the vehicle instructions.
- Whilst using the car jack always wear appropriate personal protective equipment.

-
- Before each use examine the car jack. If you notice loose parts or damage, do not use the car jack. In this case, do not use the car jack; a qualified professional should examine it.
 - The car jack should only be used for the lifting and lowering of vehicles; a lifted vehicle should be supported on a support device with an adequate load capacity. If the car jack is being used as a support device for a vehicle, it can be damaged and lead to personal injury.
 - When the vehicle is on the car jack, do not move it. The car jack cannot handle such a strain, which can lead to personal injury and/or material damage.
 - Do not alter the car jack. Do not open the casing. The car jack does not have parts which the user can fix or change. If the user fixes or incorrectly or inappropriately uses the product, the warranty is not valid. In case of repair, contact the manufacturer through the authorised repairer detailed on the warranty certificate.
 - For repairs, only original parts for the car jack may be used. The car jack contains mechanical parts which are important to protect it from damage.
 - Do not alter the car jack and do not add parts.
 - Only move the car jack when holding the carry handle, ensuring that it is appropriately attached to the car jack.
 - Only use the car jack in dry weather conditions and in a dry environment.
 - Do not use the car jack in humid indoor areas or in the rain.
 - Never store the car jack in an area where it may fall.
 - Do not put objects in the casing.
 - Do not overload the car jack beyond the rated capacity.
 - Only use the car jack on firm, level surfaces. Do not place the car jack on a soft surface (for example on grass). Such a surface could cause the vehicle to incline or fall from the car jack, which can cause damage and/or personal injury.

- Do not approach the vehicle during lifting and lowering.
- Always lower the vehicle slowly.
- Before lifting the vehicle, apply the hand brake and place wedges under the wheels which will stay on the ground.
- Only raise the vehicle where the manufacturer recommends.
- The car jack is used with a saddle which has a diameter of approximately 54 mm and a jack handle which is 695 mm long.
- Before each use ensure that the codes and plates are visible and readable as they contain important information. If they are missing or are not readable, contact the manufacturer through the authorised repairer detailed on the warranty certificate.
- Children may not use jack. Cleaning and user maintenance must not be performed by children.
- Do not leave the jack unattended while in use.
- Keep children away from the jack.
- Do not let children play with the jack.
- Make sure that children do not play with the plastic wrapping. They may get caught in it when playing and suffocate.



WARNING!

Danger of personal injury!

Use of the car jack in exceptional or adverse conditions and environments can cause personal injury.

- Do not use the car jack in exceptional or adverse weather conditions (e.g. in very cold or hot areas, in strong winds and in strong magnetic fields), the car jack will not work properly and can cause damage. The vehicle can become unstable.
- Do not use the car jack in a potentially explosive area, near explosives and mines. Oil in the reservoir pump is flammable.
- Do not use the car jack on a ship. The vehicle will become unstable.

NOTICE**Risk of injury!**

With inappropriate handling, the car jack can be damaged.

- Always ensure safe placement of the car jack (for the correct position, study the vehicle instructions). The base must be hard (e.g. concrete), stable and flat and must withstand a load of up to 2 tonnes.
- Never clean the car jack by submerging it in water, this can damage it. Read the instructions in the “Cleaning and storage” section.
- Do not use the car jack if the casing is cracked, deformed or broken (see the “Maintenance, repair and inspection” section). Immediately stop using it and contact the manufacturer through the authorised repairer, detailed on your warranty certificate.

FIRST USE

Check the car jack and the total content

NOTICE

Risk of injury!

Be very careful when opening the packaging.

1. Ensure that all parts and accessories are present (see **picture A**).
2. Remove the car jack from the packaging and check if there is any damage to it or to any of the parts. If there is any, do not use the car jack. Contact the manufacturer through the authorised repairer, detailed on your warranty certificate.



WARNING!

Danger of personal injury!

The car jack contains small parts which can be swallowed or cause suffocation.

- Ensure all small parts are kept out of children's and animals' reach.

General overview

- Before each use ensure that the release valve **10** on the car jack is completely closed (turned clockwise), and check that there is enough oil in the oil reservoir (see "Maintenance, repair and inspection").
- Before and after each use, press on the jack handle **8** several times to ensure that the oil is evenly spread out.
- Before and after each use, ensure that the saddle **4** and/or the saddle sleeve **3** is properly mounted on the saddle holder **1**.

Saddle assembling/dismantling



WARNING!

Damage and injury risks!

If the saddle is removed from the saddle holder, the load will not lift equally and stably, which can lead to personal injury and material damage.

- Never use the car jack if the saddle and/or saddle sleeve are not attached.
- Before and after each use ensure that the saddle is appropriately placed in the saddle holder. If necessary, tighten the nut and the bolt.

For assembling and dismantling the saddle a 19 mm socket wrench and a 19 mm eye key is needed.

1. With the eye key hold the wing nut of the saddle **15**, whilst unscrewing the bolt of the saddle **2** with the socket wrench.
2. Remove the wing nut of the saddle and the bolt of the saddle from the saddle structure.
3. Remove the saddle holder **1** from the saddle **4**.

For assembling the saddle follow the above-mentioned instructions in reverse order.

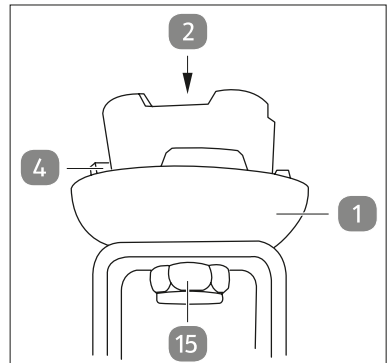

ASSEMBLING THE CAR JACK

Fitting the carry handle

On each side of the jack handle **7** sleeve is a nut, where the carry handle is attached **9**.

1. Place one of the “eyes” of the carry handle over the carry handle nut **11** (see **picture C**).
2. Carefully extend and adjust the second eye of the carry handle in the appropriate place. Some force may have to be applied in order to place the second eye of the carry handle in the correct position. The carry handle should now fit (see **picture A**).
3. Before moving the car jack, ensure that the carry handle is correctly attached. This is done by pushing the car jack forwards and backwards. The carry handle should be safely attached at this time. Otherwise, reattach the carry handle.

Assembling the jack handle

1. Align two halves of the jack handle **8** with the pin **13** on one part and with the drilled hole **14** on the other part (see **picture B**).
2. Press both parts together until you hear the pin click into place (see **picture B**).

 To take apart the jack handle, remove the jack handle from the car jack. Press the pin down to separate both halves, then press each half into the jack handle clips **12** on both sides of the car jack (see **picture A** and **B**).

Attaching the jack handle

1. Take the assembled jack handle **8** and align the end with the hole (see **picture D**) with the handle sleeve **7** (see **picture A**).
2. Press the jack handle into the jack handle sleeve and turn it so as to activate the bayonet closing (see **picture D**). Ensure that it is firmly attached.

CAR JACK USE



DANGER!

Danger of personal injury!

If the car jack is not properly placed (under a vehicle), it will not be possible to lift vehicles steadily and they could also fall suddenly. This can cause serious injury or death.

- For correct use and placement of the car jack, read the vehicle instructions.

Vehicle preparation

1. Before using the car jack, ensure that the hand brake is fully applied.
2. If the vehicle is an automatic transmission, place it in “Park”.
3. Place manual transmission vehicles into 1st gear.
4. Safely wedge the wheels (wedges are not included).

Car jack placement

1. Ensure that the lifting arm **5** is fully released.
2. Ensure that the release valve **10** is closed, so that the plug on the end of the jack handle **8** is turned fully in a clockwise direction (see **picture E**).
3. Carefully place the saddle **4** of the car jack under the lifting point recommended by the vehicle manufacturer.
4. Pump the jack handle until the top of the saddle reaches the lifting point on the vehicle.

Vehicle lifting



DANGER!

Danger of personal injury!

Never conduct work on, under or around a vehicle which is solely supported by a car jack. The vehicle is not stable and can fall suddenly and cause personal injury or even death.

- After lifting a vehicle with the car jack, always use jack stands (not included). Do not rely on the car jack to support the vehicle.
1. Once the car jack is appropriately placed on the lifting point of the vehicle, pump the jack handle **8** with smooth and full strokes.
 2. Raise the vehicle a few centimetres above the desired height.
 3. Once the vehicle is lifted, push the jack stand with an appropriate load capacity (not included) under the lifting point, which can be found in the vehicle handbook. If you are using two jack stands, place them on the same point and at the same height on both sides of the vehicle.
 4. The lifting point(s) on the vehicle must be in the middle of the jack stand(s). Place the jack stand(s) in accordance with the manufacturer's instructions and ensure that they lock appropriately into place.
 5. Slowly turn the release valve **10** anticlockwise with the help of the plug on the end of the jack handle, to lower the vehicle onto the saddle(s) of the jack stand(s). Then firmly turn the release valve clockwise, to close it (see **picture E**).
 6. Ensure that the load and the jack stands are stable and safely placed. Neither the load nor the jack stands should move. If you are unsure of the stability of the vehicle, use the car jack again to raise the vehicle and then replace and secure the vehicle on the jack stands.

Vehicle lowering



DANGER!

Danger of personal injury!

If there are people, animals or other objects in or under the vehicle, before lowering, this can cause personal injury or even death.

- Always ensure that the area under the vehicle is clear, that there are no people, animals or objects under the vehicle, before lowering.
 - Always use the car jack to lower the vehicle.
1. Place the saddle **4** under the lifting point.
 2. With the plug on the end of the jack handle **8** turn the release valve **10** clockwise (see **picture F**).
 3. Pump the jack handle to lift the vehicle somewhat above the saddle(s) of the jack stand(s) (not included).
 4. Remove the jack stands.
 5. Very slowly turn the release valve anticlockwise, to lower the vehicle to the ground.
 6. Remove the car jack and ensure that the lifting arm **8** is fully released.
 7. Close the release valve by turning it clockwise.

Troubleshooting

Problem	Possible reasons	Solution
The car jack will not lift the vehicle.	- Low on oil.	- Add oil (see “Maintenance, repair and inspection” section).
	- Dirty oil is blocking the release valve.	- Change the oil (see “Maintenance, repair and inspection” section).
	- The release valve is not fully closed.	- Fully close the release valve.
The car jack will not lower the vehicle.	- The release valve is not fully open.	- Fully open the release valve.
	- Too much oil is in the oil reservoir.	- Release a little oil from the oil reservoir (see “Maintenance, repair and inspection” section).
	- Verschmutztes Öl blockiert das Ablassventil.	- Change the oil (see “Maintenance, repair and inspection” section).
Visible damage.	- Broken or bent parts due to falls or other knocks.	- A qualified professional should look at and/or fix the car jack.
Oil leak from the car jack.	- The reservoir or the gaskets are faulty.	- Contact the manufacturer through the authorised repairer detailed on the warranty certificate.
The car jack is making an unusual noise during lifting and lowering of the vehicle.	- Movable parts of the car jack are not fully greased.	- The reservoir is damaged.
	- Oil the affected areas.	- Contact the manufacturer through the authorised repairer detailed on the warranty certificate.

MAINTENANCE, REPAIR AND INSPECTION



CAUTION!

Damage and injury risks!

When the car jack is being used in a working area where oil is spilled, it can slip and cause material damage and/or personal injury.

- Thoroughly clean the area where work will be carried out or where the vehicle will be lowered and raised.
- Regularly lubricate all moving parts.
- Oil in the oil reservoir **17** should be changed every 3 years.
- Before each use examine the car jack.
- Check whether there are any cracks, damaged welds and if there are pieces missing and/or if they are loose and/or damaged. If the car jack is damaged or in any way deformed, do not use it.
- If you believe that the car jack was incorrectly loaded, the manufacturer should immediately check it. Contact the manufacturer through the authorised repairer, detailed on your warranty certificate.
- If there are any issues with the car jack or there are parts missing, it is damaged, deformed or broken, contact the manufacturer through the authorised repairer detailed on the warranty certificate.

Adding oil



WARNING!

Damage and injury risks!

If too much oil is added to the reservoir, the car jack will become overloaded and can cause injury.

- Only fill as much oil in the reservoir as recommended in this section.

NOTICE

Risk of injury!

If using incorrect oil, the car jack can be damaged or broken.

- Only use the oil which is specified in the “Technical details” section.

1. Fully release the car jack and ensure that the release valve **10** is turned clockwise, then lift the cover plate **6**.
2. Carefully lift and with a screwdriver, remove the oil filler plug **16** of the oil reservoir **17**.
3. Add oil, so that it covers the reservoir piston. Ensure oil is not spilled. If necessary, use a funnel to add oil.
4. Clean the oil filler plug and put it back in the oil reservoir ensuring that it is in the correct position.
5. Lower the cover plate.

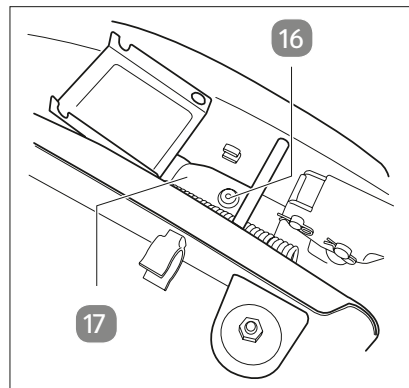

Changing oil



- Check the oil at least once a year; if dirt or foreign objects are noticed, change the oil.
- If using the car jack regularly, the oil should be checked regularly.

1. Fully release the car jack and ensure that the release valve **10** is turned clockwise, then lift the cover plate **6**.
2. Carefully lift and with a screwdriver, remove the oil filler plug **16** of the oil reservoir **17**.
3. Stand the car jack up so that the used oil runs out of the oil reservoir, then dispose of the oil in accordance with local regulations.
4. Clean spilled oil from the car jack.
5. Whilst the car jack is standing, add the recommended oil (see the “Technical details” section), so that the reservoir piston is covered.
6. Clean the oil filler plug and replace it in the oil reservoir ensuring that it is firmly back in its place.

CLEANING AND STORING

NOTICE

Danger due to incorrect use!

With inappropriate handling, the car jack can be damaged.

- Do not use abrasive cleaning products, brushes with metallic or nylon bristles, sharp or metallic cleaning aids, such as knives, hard scrapers and so on. They can cause damage to the exterior.
- Always store the car jack safely. The car jack should not be stored in a position from which it could fall.
- The car jack should be cleaned with a lightly oiled cloth.
- Always ensure that the lifting arm **5** is fully lowered and that the jack handle handle **8** is safely attached to the car jack in the jack clips **12** (see **picture A**).
- Store the car jack in a cool, dry place, away from direct sunlight and extreme temperatures (hot or cold), weather conditions (such as rain) and chemicals and destructive fumes.
- Store the car jack in a safe place, away from children and animals.

TECHNICAL DETAILS

Model:	FLX-WH-01
Lowest saddle height	
– with the sleeve:	150 mm
– without the sleeve:	135 mm
Highest saddle height with the sleeve	
– with a load:	350 mm
– without a load:	357 mm
Highest saddle height without the sleeve	
– with a load:	335 mm
– without a load:	342 mm
Weight:	9,7 kg
Size (L × W × H):	483 x 189 x 150 mm
Oil type:	SAE 10
Life span:	5 years

As we are continually developing and enhancing our products, changes may be made to the technology and design.

These instructions can be downloaded as a PDF file from our website www.flexxtrade.de

WASTE DISPOSAL

Disposing of packaging



Sort the packaging before you dispose of it. Dispose of the cardboard with the recycled paper service and plastic with the appropriate collection service.

Disposal of the car jack

- When the car jack is no longer usable, discard of it according to the rules of your city or country.

DECLARATION OF CONFORMITY

EU-Konformitätserklärung

EC-Declaration of Conformity

Hiermit erklären wir, dass die Bauart des nachfolgend bezeichneten Gerätes den unten genannten einschlägigen EU-Richtlinien entspricht und die Serie entsprechend gefertigt wird.

We hereby confirm that the appliance described below is in compliance with the governing EC-regulations as mentioned in this form and mass production will be effected accordingly.

Artikelbezeichnung: Article Description:	Rangier-Wagenheber Car Trolley Jack
Typ / Model:	FLX-WH-01
Technische Angaben: Technical data:	maximale Tragkraft 2 Tonnen max. load 2 t
Jahr der Anbringung der CE-Kennzeichnung / year of affixing the CE Marking: 2018	

Einschlägige EU-Richtlinien / Governing EU-regulations

EG Richtlinie 2006/42/EG

Harmonisierte EN-Fach- und Grundnormen / Harmonized EN-standards and general standards

Der Artikel entspricht folgenden, zur Erlangung des CE-Zeichens erforderlichen Normen:

The article is in compliance with the standards mentioned below, which are basic conditions to obtain the CE-mark

EN 1494:2000+A1:2008

EN ISO 12100

Person, die bevollmächtigt ist, die technischen Unterlagen zu erstellen:

Person, responsible for creating of the technical documents:

Hr. Holger Lemke
i.V. Leitung Qualitätsmanagement / Head of QA Dep.

Ausstellungsdatum

Date of issue

23.01.2018

FLEXXTRADE GmbH & CO KG

Hofstrasse 64

40723 Hilden

Germany

Hr. Udo Schmitz
Geschäftsführer / Managing Director



Great care has gone into the manufacture of this product and it should therefore provide you with years of good service when used properly. In the event of product failure within its intended use over the course of the first 3 years after date of purchase, we will remedy the problem as quickly as possible once it has been brought to our attention. In the unlikely event of such an occurrence, or if you require any information about the product, please contact us via our helpline support services, details of which are to be found both in this manual and on the product itself.



PRODUCED IN CHINA FOR:

ALDI STORES LTD. PO BOX 26, ATHERSTONE
WARWICKSHIRE, CV92SH.

ALDI STORES (IRELAND) LTD.
PO BOX 726, NAAS, CO. KILDARE.
Visit us at www.aldi.com

AFTER SALES SUPPORT

99254



00800/78747874



00800/78747874



flexxtrade-gb@teknihall.com

flexxtrade-ie@teknihall.com

MODEL:
FLX-WH-01

02 / 2020

3
YEAR
WARRANTY